

# ASBV-1000 - 65A

## PART LIST

PART NO.	PART NAME	Q'TY	MATERIAL	REMARK
1	BODY	1	SCMN2	
2	FLANGE	1	SS41	
3	SEAT GUIDE	1	SM45C	NOTE : TURNER OVER
4	INFLATABLE GASKET(SEAT)	1	EPDM	
5	SEAT RING	1	SM45C	
6	BALL PAD	1	SCMN2	
7	BALL	1	SCMN2	
8	SPRING PIN	2	SMP	OUT SIDE : TURNER OVER
9	BOTTOM SHAFT	1	SM45C	
10	O-RING	2	NBR	
11	BOTTOM COVER	1	SS41	
12	GUIDE BUSH	2	PP	
13	O-RING	2	NBR	
14	SHAFT	1	SM45C	
15	O-RING	1	NBR	
16	HAXAGON BOLT	8	SS400	
17	HAXAGON BOLT	2	SS400	
18	HAXAGON LANCH BOLT	4	SUS304	
19	HAXAGON BOLT	4	SS400	
20	ACTUATOR	1	HP-100	
21	AIR FILTER REGULATOR	1	AFR-200	
22	SOLENOID VALVE	1	VFN-2120	
23	QUICK EX VALVE	2	AQ-2000	
24	LIMITS SWITCH	1	APL-210N	
25	CAM	1	SS41	
26	MECHANICAL VALVE	1	KVM-230	
27	SOL BLOCK	1	AL	
28	MC VALVE BRAKET	1	SUS304	
29	SOL VALVE BRAKET	1	SS41	

### NOTE

FLANGE CODE : ANSI 150# /mm

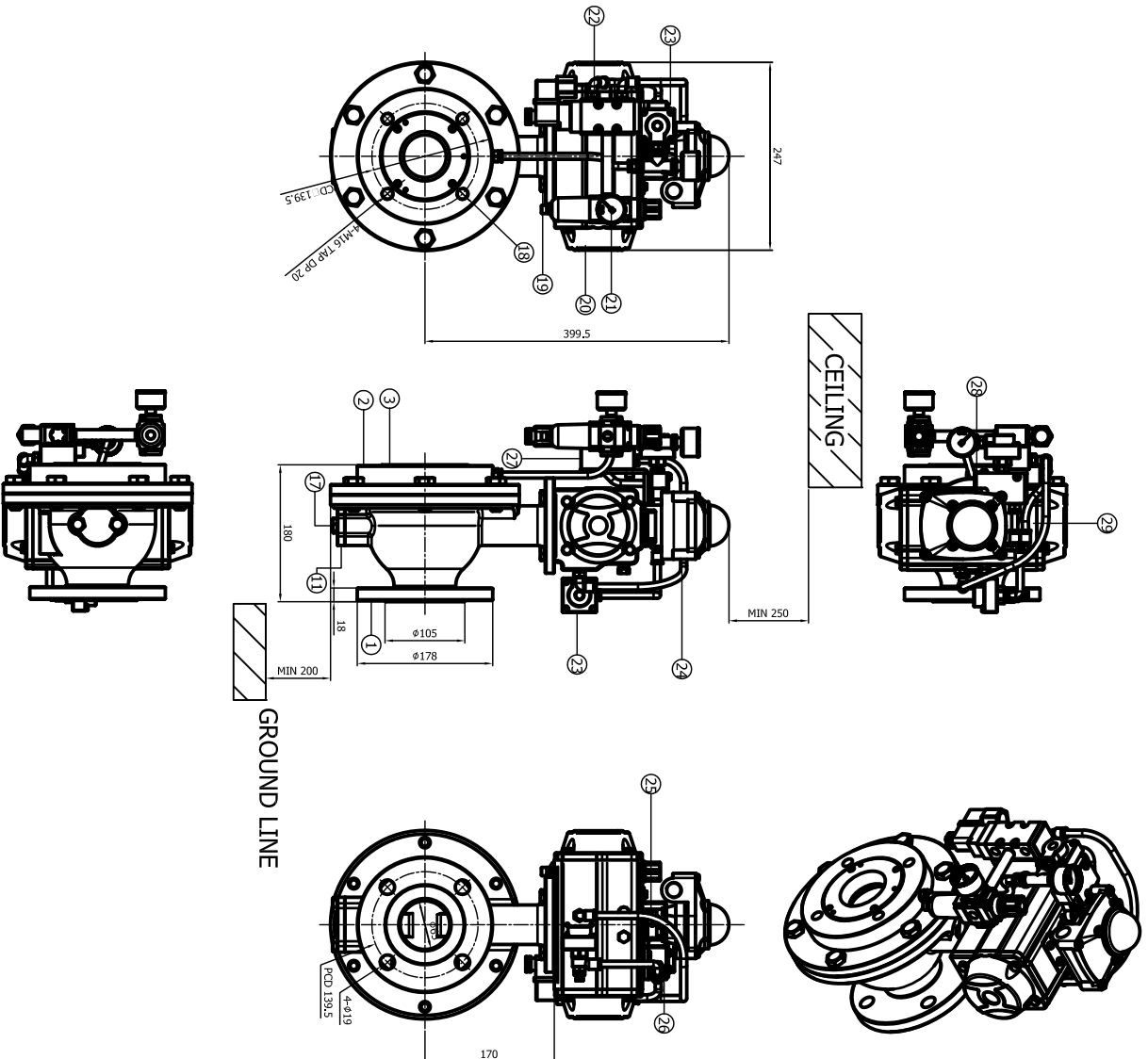

## SAM SUNG CONTROL VALVE

ASBV-1000 - 65A

SIZE	DESIGN BY	DATE	DWG NO.	MODEL NO.	REV
A4	LEE SANG YOON	2014. 03. 21.	DXF-ASBV-65	ASBV-1000-65A	01

SCALE	N/S	UNITS	mm	SHEET NO.	01